

PROCESS RECIPROCATING COMPRESSORS



DRESSER-RAND[®]

Bringing energy and the environment into harmony.[®]



Process reciprocating compressors

*Total solutions backed by
a century of experience.*



Foundation-mounted HHE-VB unit with spread center frame that provides additional maintenance access between cylinders. Note manifolded suction pulsation vessels with banded insulation.

BUILDING ON A HERITAGE OF FIELD- PROVEN ENGINEERING AND SUPERIOR SERVICE

For more than 100 years, Dresser-Rand has been a world leader in energy conversion technology, designing, manufacturing, selling, and servicing a wide range of field-proven reciprocating and centrifugal compressors, steam turbines, expanders, multiphase turbine separators, and control systems. We have approximately 23,500 operating reciprocating units – including reciprocating compressors, gas engines and gas field compressors/separable products – at work in a variety of difficult process applications including ammonia, acid gas, butadiene, butane, carbon dioxide, chlorine, ethylene, hydrogen, hydrogen sulfide, methane, bone dry nitrogen, oxygen, pentane, propylene, sulfur dioxide, and vinyl chloride.

Dresser-Rand offers a complete line of reciprocating compressors, many built to strict API and ISO standards, and all backed by a global service network. These comprehensive capabilities allow us to manage a wide range of energy conversion projects for our clients.

We manufacture our reciprocating compressors at state-of-the-art facilities in Painted Post, New York; Peterborough, United Kingdom;

Shanghai, China; and Naroda, India. This global presence allows Dresser-Rand to provide the most flexible and responsive service, regardless of your location.

USING ONE SOURCE ENSURES TOTAL SYSTEM INTEGRATION

We can engineer, manufacture, procure, test, deliver, install, operate, and maintain your entire compressor system. Our extensive application experience with all major drive systems—including motors, engines and turbines—allows us to precisely match the drive train to the compressor for maximum efficiency and reliability.

We also provide all compressor accessories, piping and packaging necessary to meet your total process and installation requirements. Our packaged units are ready for modular installation, with all compressor drive, lubrication, coolant, pulsation dampening, and control systems in place. This integrated approach simplifies ordering, delivery and installation; reduces your coordination time and expense; lowers your engineering and construction costs; and provides single-source accountability.

Our project management expertise and systems ensure compliance with specifications, process and operational excellence, shortest system delivery cycles, and on-time shipment.



12,000 hp, eight-cylinder HHE-VL in our factory assembly area being prepared for barover and rod runout alignment checks.

A WORLD OF ENERGY CONVERSION SOLUTIONS

As impressive as our equipment is, Dresser-Rand can offer you much more. Our capabilities include a wide array of products and service options that let you focus on your core business and leave the rest to us.

After studying your requirements and considering a variety of options, we'll select the most reliable, cost-effective solution. Maintaining a flexible perspective allows us to develop creative, field-proven solutions that include all aspects of

a project, from initial concept to equipment retirement. Services include concept engineering, process audits, product support, and contract compression options, as well as

- **revamped and remanufactured equipment** to adapt any brand of existing reciprocating machinery to meet your present operating conditions and requirements;

- **product upgrades** to optimize your equipment's performance and reliability; and

- **engineering evaluations and field analysis** for problem solving using advanced diagnostics coupled with years of reciprocating compressor experience and expertise to analyze the data and recommend total solutions to solve any operational problem or improve efficiency and reliability.

Producing the energy and products you use every day



Dresser-Rand reciprocating compressors and integral gas engines are at work right now in these applications:



- **REFINING**—Hydrogen and hydrocarbon mixtures are compressed to produce clean gasoline, jet and diesel fuels, heating oils, lubricants, asphalt, and other related refinery products. In addition,

Dresser-Rand compressors are used to help collect and separate toxic gases which otherwise may be harmful to our environment.



- **PETROCHEMICAL**—Thousands of products, ranging from plastic to shampoo, are created by the compression of various gaseous mixtures in many different chemical processes.

- **NATURAL GAS TRANSMISSION**—Most of the natural gas that heats our homes and cooks our food is gathered, processed, stored, and transported through the international network of pipelines by Dresser-Rand compressors.

- **ENHANCED OIL RECOVERY**—Dresser-Rand units compress carbon dioxide, hydrocarbon gas, or acid gas to high pressures for injection into oil wells to either increase oil production or re-inject gas to minimize environmental pollution.

- **U.S. NAVY**—Dresser-Rand is certified to build compressors for the U.S. Navy's nuclear submarine program and is a major supplier of other types of shipboard air compressors.

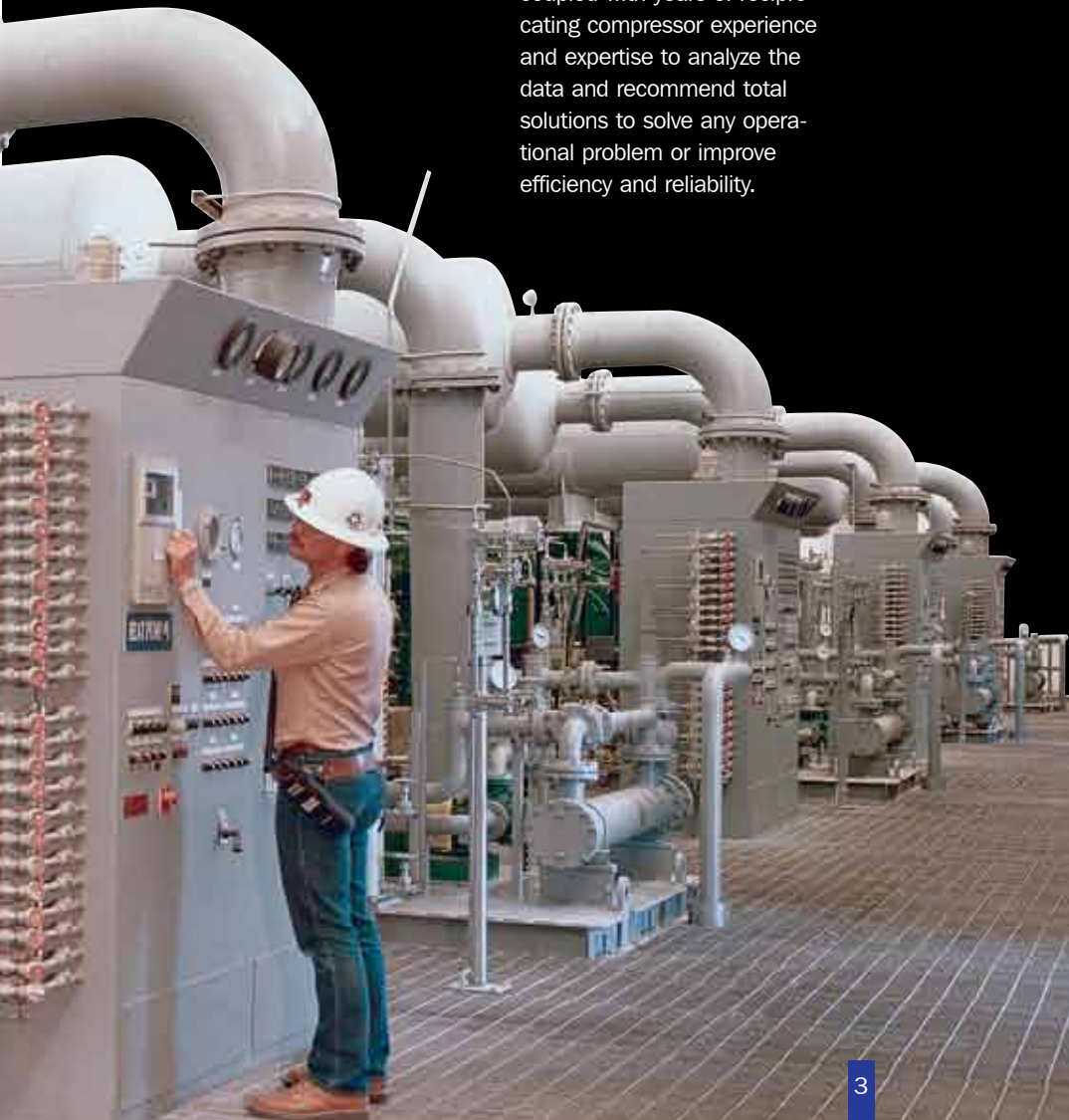



G

lobal service and quality components

*We build them right,
then we back them right.*

PRODUCT SERVICES THAT DELIVER TOTAL SUPPORT

Dresser-Rand uses its state-of-the-art technology and total solution capabilities and applies them to all makes and models of installed process reciprocating compressors. This same technology is used to design and build our new equipment. So no matter what manufacturer's nameplate is on your compressor, the dedicated professionals at our network of service centers are ready to keep it running with responsive, reliable technical support 24 hours a day, anywhere in the world.

Services include **revamping and remanufacturing** existing or out-of-service reciprocating compressors to fit your present operating conditions; expert **repair service** from factory-trained technicians through our worldwide network of service centers; **replacement and upgraded parts** that include the latest design improvements; around-the-clock **field service**, including installation assistance or complete installation; **revamps and rerates** that use the latest technology to modernize equipment to meet changes

in your process or operating conditions while enhancing reliability and efficiency; and **training**, either at your location or one of ours.

STRATEGICALLY LOCATED FOR MAXIMUM RESPONSE

Our employees throughout the world possess the experience and vision to create the best solutions for your energy conversion needs, along with the engineering and manufacturing expertise to achieve those solutions on time and within your budget. To meet your changing needs, we have stationed integrated teams throughout the world. These teams work with experts at Dresser-Rand's more than 30 manufacturing and technology centers.

COMPUTER DESIGNED, PRECISION BUILT

We have streamlined every step of our process to bring you the best solution months earlier than was previously possible. You will see this efficiency right from the start. Our proprietary Product Configurator software enables us to work directly with our clients' engineers to quickly and easily analyze various equipment scenarios, then generate complete specs, drawings and a bill of materials. As a result, our clients get customized solutions in record time.

Our Unigraphics® CAD/CAM system further enhances product quality and reduces cycle time. It allows our engineers to work closely with each other for better coordination at all project stages.

These and other tools enable us to engineer every component of all Dresser-Rand reciprocating compressors for superior reliability in the most demanding applications.



DEA coordinate measuring machine



The quality of rolled threads can lead to major field problems. Our new digitally controlled thread rolling machine is used in the manufacture of all piston rods.

MAXIMIZING THE PERFORMANCE OF EVERY COMPONENT

A valve technology leader—Dresser-Rand's continuous research and development has produced a new generation of efficient and highly reliable valves. Using proprietary software and an extensive test laboratory, we carefully analyze valve dynamics under all operating conditions. Our comprehensive analysis maximizes valve reliability and efficiency by predicting potential problems that were not previously detectable in the design stage. Dresser-Rand valve innovations include new-technology materials that maximize reliability under harsh operating conditions.

Dresser-Rand's Infinite Step Capacity (ISC)—delays suction valve closing to reduce power usage at off-design process operating conditions. This system can significantly reduce operating costs by eliminating bypass waste.

Heavy-duty frame and running gear—Crankshafts are high-tensile strength alloy steel forgings, fully stress relieved. All journals are precision ground to exacting tolerances. A rigid cast-iron frame, with suitably ribbed bearing supports, eliminates frame deflection and maintains critical alignment under all operating conditions. Rugged crossheads have full-floating pins that are easily replaceable and are case hardened for maximum service life.

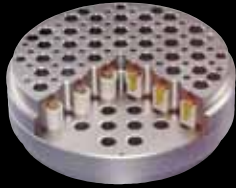

Forged steel connecting rods—High-strength die-forged steel connecting rods are rifle drilled for reliable crosshead lubrication.

Robust balanced-opposed design—Minimizes unbalanced reciprocating forces and moments to reduce vibration and maximize operating life.

A complete line of efficient and reliable water-cooled cylinders—Each cylinder is designed to meet your specific operating requirements and ensure the longest operating life for all cylinder components at all operating conditions.

Rolled thread piston rods—Precision-controlled rolled threads provide strength in heavy-duty service. Standard piston rod material is carbon steel, with other materials and coatings available as required for specific process applications.

DuraWear™ Performance Parts—Our complete line of premium-quality components improves the performance and extends the life of reciprocating compressor cylinders. Parts include piston rings, rider bands, rod packing rings, oil wiper rings, and complete packing cases available for virtually any application.

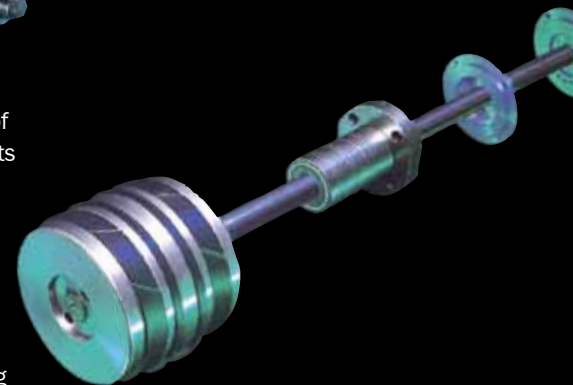
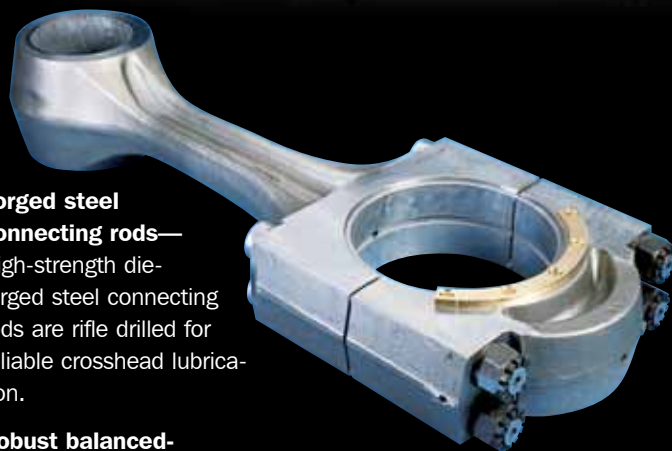
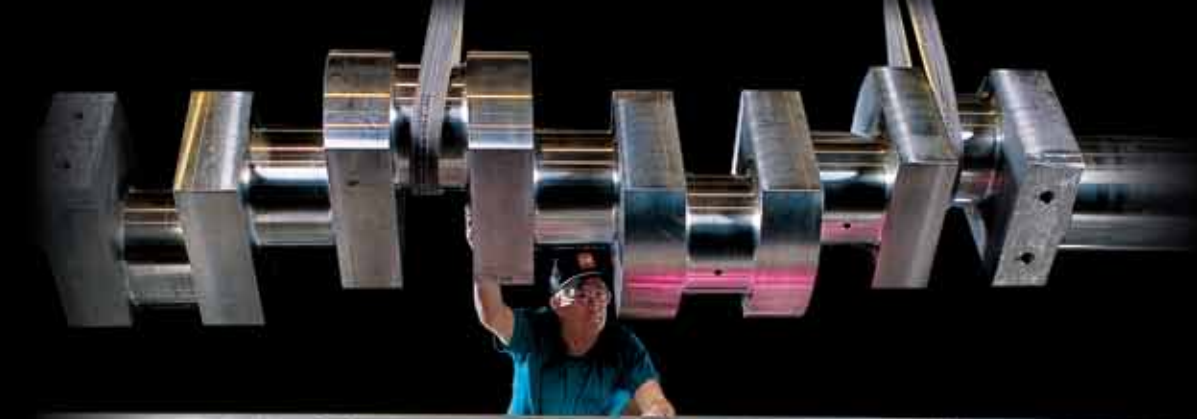



A wide range of quality-built compressors

Field-tested designs we continue to improve.

A RECIPROCATING COMPRESSOR FOR EVERY APPLICATION

Dresser-Rand reciprocating compressors are available with up to 10 crank throws, as single-throw or balanced-opposed configurations. We custom engineer each unit by designing each cylinder and valve, and select other components to meet your specific operating requirements. Our factory experts check all critical clearances and dimensions, and perform inspections and tests to prevent installation problems. The result is a reciprocating compressor that meets or exceeds client specifications, while delivering unmatched efficiency and reliability.

ESH/PHE/HSE

Reciprocating Compressors (5 TO 1,000 HORSEPOWER)

ESH compressors are single-throw units, available as 7", 9", or 11" strokes. The PHE compressor is a 7" stroke, two-throw, balanced-opposed unit. The HSE compressor is a two- or four-throw balanced-opposed unit available as 9" and 11" stroke.

More than 6,000 units have been installed in the most severe chemical, process and natural gas applications. The ESH, PHE and HSE frames are either belt, gear, or direct driven and are available as foundation-mounted units or skid-mounted packages with every component engineered to provide high reliability and low maintenance. Maximum efficiency is ensured by the superior flow performance of our valves, as well as control systems that automatically match compressor performance to the process requirements.

HHE/BDC

Reciprocating Compressors (200 TO 45,000 HORSEPOWER)

The HHE/BDC line of balanced-opposed reciprocating compressors has established a worldwide record of efficiency and reliability in more than 6,000 process gas installations. The valve and control features highlighted above are also incorporated in the design of these larger units. Using finite element analysis (FEA) and strain gauge testing, both the HHE and BDC frame and cylinders have been designed for maximum reliability and performance along with easy maintenance access. Additionally, the piston rod to crosshead and piston rod to piston fastening methods have been modernized for easier, more reliable installation and maintenance. HHE and BDC compressors are available up to 17" stroke and 10 crank throws. The variable crank design of the HHE compressor permits odd (3, 5, 7) cylinder configurations that minimize wearing parts and plot plan requirements.



Skid-mounted, 125 hp, two-cylinder PHE package being prepared for shipment. Depending on the physical size of the compressor, skid mounting saves field assembly time.



In February 2005, Dresser-Rand provided APCI with two skid-mounted, HHE-VL compressors, each including a frame lube oil console attached to the skid.

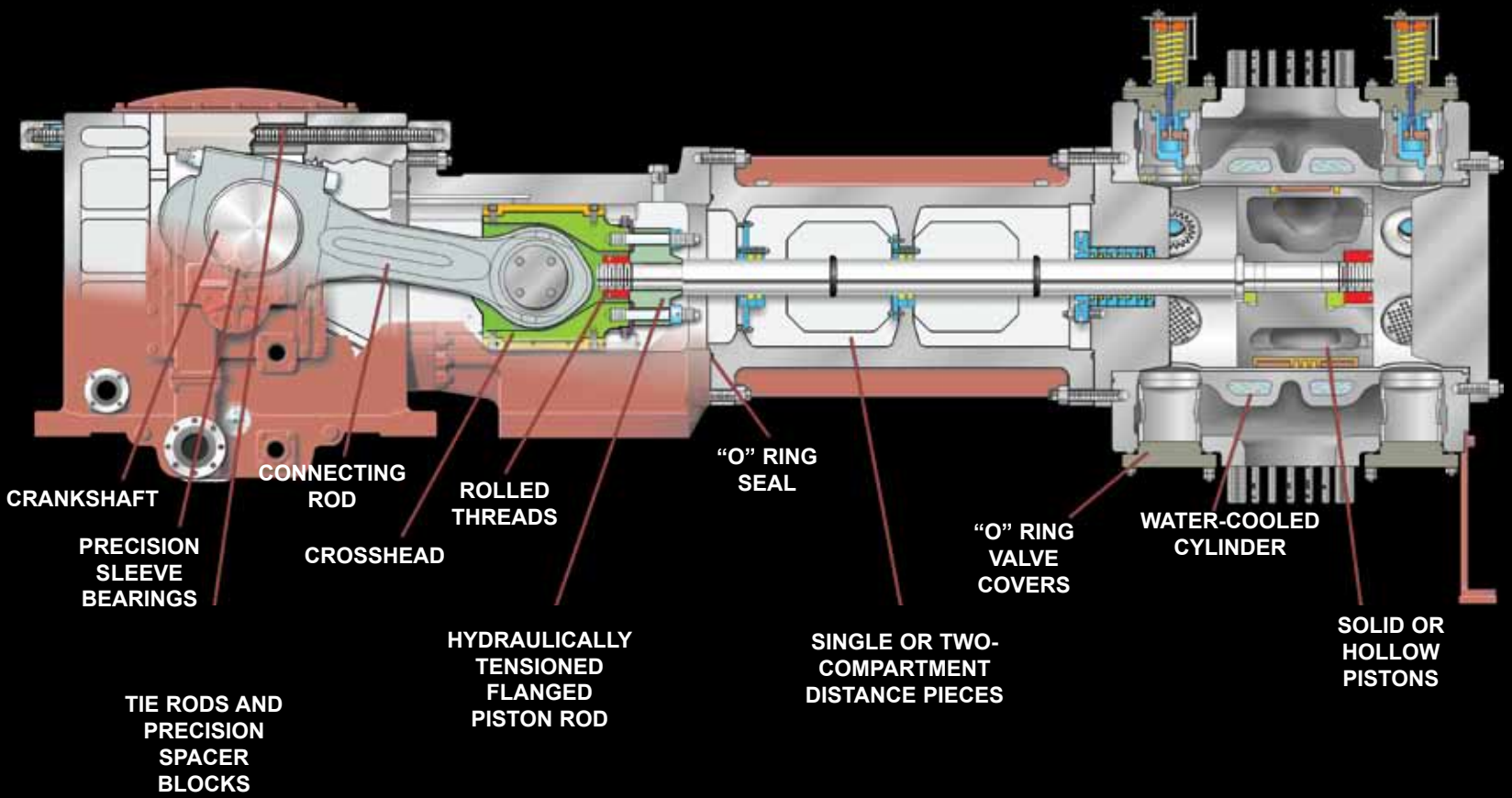

Design and construction
 details of the HHE and BDC



DRESSER-RAND®

Bringing energy and the environment into harmony.®

For a complete list of D-R products and services, visit www.dresser-rand.com or contact us at the following locations:

CORPORATE HEADQUARTERS

Dresser-Rand

West8 Tower, Suite 1000
10205 Westheimer Road
Houston, Texas 77042
Tel: (Int'l +1) 713-354-6100
Fax: (Int'l +1) 713-354-6110

Dresser-Rand

112, Avenue Kleber
Cedex 16
Paris 75784 France
Tel: (Int'l +33) 156 26 71 71
Fax: (Int'l +33) 156 26 71 72

Email: info@dresser-rand.com

REGIONAL HEADQUARTERS

The Americas

West8 Tower, Suite 1000
10205 Westheimer Road
Houston, Texas 77042
Tel: (Int'l +1) 713-354-6100
Fax: (Int'l +1) 713-354-6110

EMEA

(Europe, Middle East & Africa)
Dresser-Rand S.A.
31 Boulevard Winston Churchill
Cedex 7013
Le Havre 76080 France
Tel: (Int'l +33) 2-35-25-5225
Fax: (Int'l +33) 2-35-25-5366/5367

Asia-Pacific

Dresser-Rand Asia Pacific Sdn Bhd
Unit 9-4, 9th Floor
Bangunan Malaysian Re
17 Lorong Dungun
Damansara Heights
50490 Kuala Lumpur, Malaysia
Tel: (Int'l +60) 3-2093-6633
Fax: (Int'l +60) 3-2093-2622

Manufacturing Operations

Painted Post, NY, USA

Tel: (Int'l +1) 607-937-2011
Fax: (Int'l +1) 607-937-2905

Dresser-Rand Company Ltd. Peterborough, Cambridgeshire United Kingdom

Tel: (Int'l +44) 1733 292200
Fax: (Int'l +44) 1733 292300

Dresser-Rand India Pvt. Ltd. Naroda (Ahmedabad), India

Tel: (Int'l +91) 79 282 1692
Fax: (Int'l +91) 79 282 0266
E-mail: drindia@dresser-rand.com

Dresser-Rand Engineered Equipment (Shanghai) Ltd. Shanghai, People's Republic of China

Tel: (Int'l +86) 21-6591-8050
Fax: (Int'l +86) 21-6591-7720



©2009 Dresser-Rand. DRESSER-RAND is a registered trademark of Dresser-Rand Group Inc. Unigraphics is a registered trademark of Unigraphics Solution, Inc. Printed in U.S.A.

This brochure comprises a general overview of the Dresser-Rand products described herein. It is solely for informational purposes, does not represent a warranty of the information contained herein, and is not to be construed as an offer to sell or solicitation to buy. Contact Dresser-Rand for detailed design and engineering information suitable to your specific applications. Dresser-Rand reserves the right to modify its products and related product information at any time without prior notice.