

RLA / RLVA

Single-Stage Steam Turbine

These rugged, versatile mechanical drive steam turbines are typically used for lube oil pumps, feed water pumps, fans, and generators for applications from 1 HP (0.745 kW) to 1000 HP (745 kW). The RLA, horizontal orientation, and RLVA, vertical orientation, radial split casings comply with API 611, have inlet covers with integral steam chests, 360-degree arc of admission, and exhaust casings formed by two heavily ribbed castings.

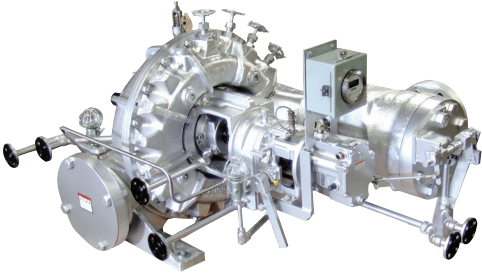

Hand Valves

The multiple hand valve feature allows part load, overload, and minimum inlet/maximum back pressure control for flexible operation and increased part-load efficiency. The appropriate number of hand valves is determined by steam and operating conditions and application load requirements.



Overspeed Trip System

The overspeed trip actuating mechanism is a bolt-type, spring-restrained weight, positioned in the turbine shaft. At a pre-selected speed the bolt is released to unlatch the overspeed trip valve and completely stop the turbine.

The overspeed trip valve is a force-actuated, single-seated, piloted positive shutoff that is independent of the governor valve. It is designed to minimize pressure drop in the open position and instantly shut off steam when tripped by the overspeed trip mechanism. The valve can be manually reset against full-line pressure.

Governing Systems

The Woodward TG series, constant speed, oil relay governor is standard equipment for RLA/RLVA steam turbines. Other governing systems can be supplied if required to meet operating conditions or NEMA D specifications.

Rotors, Bearings, Sealing Glands

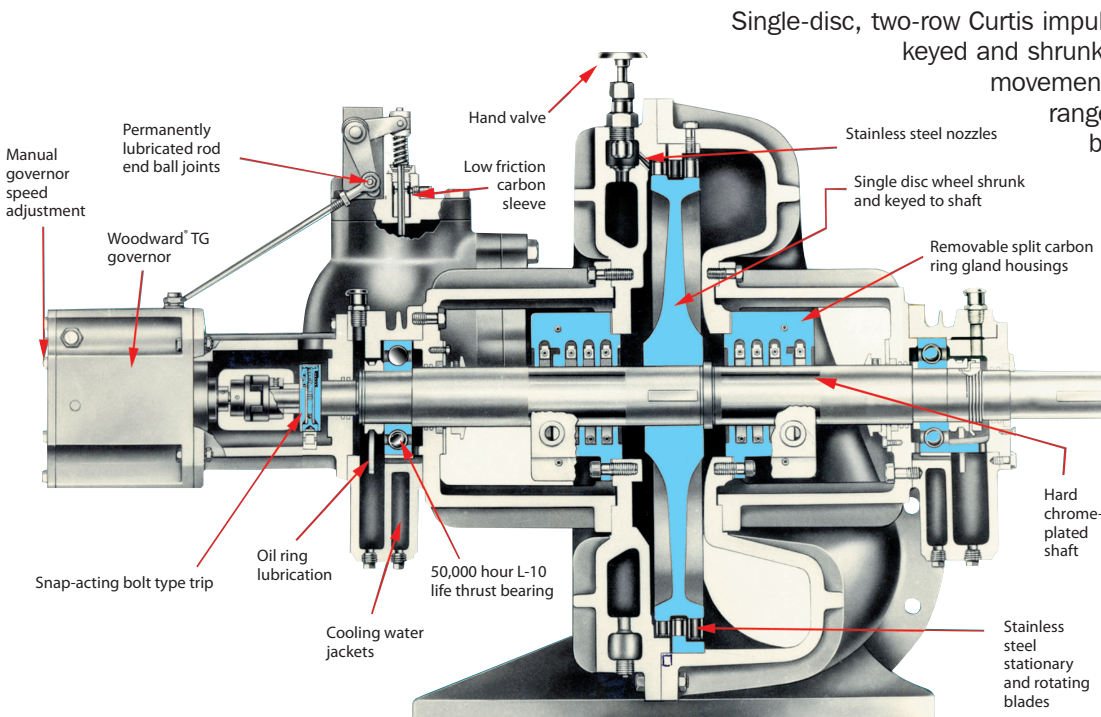

Single-disc, two-row Curtis impulse-type wheels, shouldered, keyed and shrunk to the shaft, prevent wheel movement throughout the turbine speed range. Turbine wheels are located between the bearings. Balancing and vibration testing are in compliance with the dynamics section of API 611.

Antifriction bearings are standard on RLA/RLVA turbines rated for 50,000-hour L-10 life for increased reliability. Bearings are remote from the hot casing allowing operation at higher steam temperatures without lube oil or water cooling systems. Split carbon ring sealing glands are readily accessible and easy to remove without disturbing other parts of the turbine.

For more information on **RLA/RLVA single-stage steam turbines**, contact our Worcester, MA Technology Center at:

Dresser-Rand
299 Lincoln Street
Worcester, MA 01605
Tel: 1-888-268-8726
Fax: 508-595-1788

For a complete list of D-R products and services, visit us at www.dresser-rand.com or contact us at the following locations:

Dresser-Rand Corporate Headquarters

West8 Tower Suite 1000
10205 Westheimer Road
Houston, TX 77042 USA
Tel: (Int'l +1) 713-354-6100
Fax: (Int'l +1) 713-354-6110
email: info@dresser-rand.com

112, Avenue Kleber
75784 – Paris Cedex 16
Tel: (Int'l +33) 156 26 71 71
Fax: (Int'l +33) 156 26 71 72
email: info@dresser-rand.com

Regional Headquarters

The Americas
Dresser-Rand
West8 Tower Suite 1000
10205 Westheimer Road
Houston, TX 77042 USA
Tel: (Int'l +1) 713-354-6100
Fax: (Int'l +1) 713-354-6110

EMEA
(Europe, Middle East, Eurasia, Africa)
Dresser-Rand S.A.
31 Boulevard Winston Churchill
Cedex 7013
Le Havre 76080 France
Tel: (Int'l +33) 2-35-25-5225
Fax: (Int'l +33) 2-35-25-5366 / 5367

Asia-Pacific
Dresser-Rand Asia Pacific Sdn Bhd
Unit 8-1, 8th Floor
Bangunan Malaysian Re
17 Lorong Dungun
Damansara Heights
50490 Kuala Lumpur, Malaysia
Tel: (Int'l +60) 3-2093-6633
Fax: (Int'l +60) 3-2093-2622

©2007 Dresser-Rand. This document comprises a general overview of the products described herein. It is solely for informational purposes, does not represent a warranty or guarantee of the information contained herein and is not to be construed as an offer to sell or a solicitation to buy. Contact Dresser-Rand for detailed design and engineering information suitable to your specific applications. Dresser-Rand reserves the right to modify its products and related product information at any time without prior notice.

Standard Features

- Direct drive, oil relay (Woodward TG series) or NEMA Class A constant speed governor
- Overspeed mechanical trip and shut off system
- Manual speed changer
- Curtis type wheel
- Removable carbon ring sealing glands
- Built-in removable steam strainer
- Lagging blanket insulation (API applications)

Optional Features

- NEMA Class D governors and variable speed governors
- Solenoid trips for remote shutdown
- High backpressure trip
- Forged steel wheels
- Manual nozzle hand valves
- Special and double shaft extensions
- Copper-free construction for corrosive atmosphere
- High back pressure construction to 165 psig

Maximum Capabilities

Model	Power HP (kW)	Inlet Pressure PSIG ₁ (BARG)	Inlet Temp °F (°C)	Exhaust PSIG ₂ (BARG)	RPM	Inlet Dia. In (mm)	Exhaust Dia. In (mm)
RLA-12L	106 (79)	670 (46)	825 (440)	105 (7)	6000	1.5 (40)	3 (75)
RLA-16L	242 (180)	670 (46)	825 (440)	165 (11)	5000	1.5 (40)	4 (100)
RLA-16E	320 (239)	670 (46)	825 (440)	165 (11)	5000	2 (50)	4 (100)
RLA-20L	260 (194)	670 (46)	825 (440)	165 (11)	4300	2 (50)	6 (150)
RLA-23L	1000 (746)	670 (46)	825 (440)	165 (11)	4300	3 (75)	8 (200)
RLA-23E	1000 (746)	700 (46)	825 (440)	165 (11)	4300	4 (100)	8 (200)

RLVA Same sizes and capabilities as RLA models but in vertical orientation

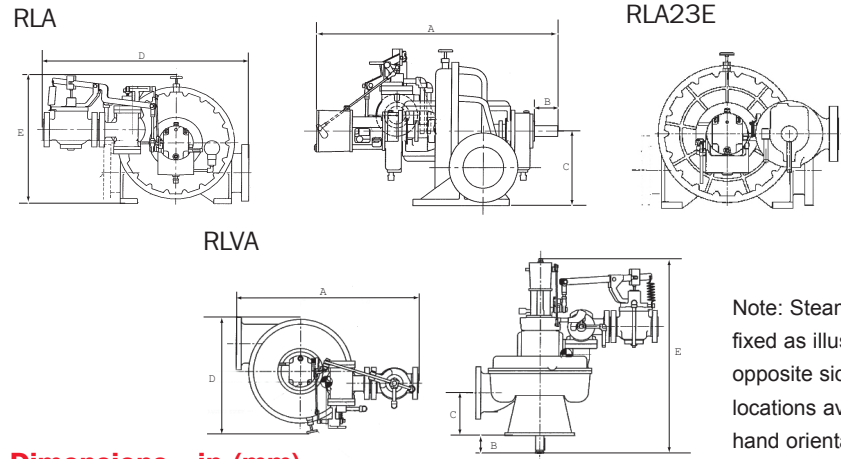

Note: Steam inlet locations are fixed as illustrated. (RLA23E is opposite side). Steam exhaust locations available as right or left hand orientation.

Dimensions - in (mm)

RLA	RL12L	RL16L	RL16E	RL20L	RL23L	RL23E
A	39 (997)	44 (1075)	44 (1075)	44 (1075)	48 (1216)	48 (1216)
B	3 (75)	3.5 (89)	3.5 (89)	3.5 (89)	4.5 (114)	4.5 (114)
C	10 (254)	12 (295)	12 (295)	13 (333)	14.5 (368)	14.5 (368)
D	34 (853)	37 (948)	40 (1000)	42 (1070)	47 (1192)	38 (968)
E	24 (603)	26 (667)	26 (667)	28 (711)	30.5 (775)	30.5 (775)
RLVA	RLV12L	RLV16L	RLV16E	RLV20L	RLV23L	RLV23E
A	33.5 (853)	37 (948)	40 (1000)	42 (1070)	47 (1192)	35 (886)
B	3 (75)	4.5 (114)	4.5 (114)	4.5 (114)	4.5 (114)	4.5 (114)
C	10 (254)	11 (283)	11 (283)	10 (254)	11 (280)	11 (280)
D	20 (500)	24 (605)	24 (605)	28 (705)	30 (759)	30 (759)
E	41.5 (1953)	46 (1162)	46 (1162)	46 (1162)	50 (1275)	50 (1275)

