

AXIAL COMPRESSORS

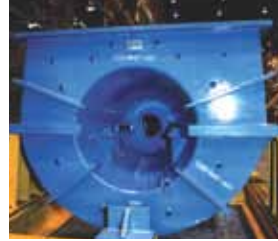

DRESSER-RAND®

Bringing energy and the environment into harmony.®



Axial compressors

Unmatched experience makes Dresser-Rand your partner of choice.

For more than 100 years, Dresser-Rand has been a world leader in energy conversion technology, designing, manufacturing, and servicing a wide range of field-proven axial, centrifugal, and reciprocating compressors, steam turbines, gas turbine packages, expanders, and control systems.

Since the early 1960s, we have built axial compressors for markets as diverse as:

- refining (FCCU main air blowers)
- steel (blast furnace blowers)
- nitric acid
- air separation
- sewage treatment
- industrial air (wind tunnels and high altitude test chambers)
- Compressed Air Energy Storage (CAES).

reflected in every product and service we offer, from new equipment to upgrades that extend the life of your installed equipment.

We'll study your requirements and perform a total lifecycle evaluation including operation and maintenance and future revamps, upgrades and retrofits to adapt all brands of rotating machinery to your present operating conditions and requirements.

With strategically located service centers in 17 countries, and a worldwide service network comprised of dedicated personnel, we can help maximize the availability of most brands of rotating equipment to you add value to your operations.

COMMITTED TO DELIVERING VALUE

D-R provides reliable, efficient energy conversion solutions that deliver the highest value to our clients. Our engineers constantly seek improvements in design, production, and testing to make our equipment even more efficient and reliable. This R&D focus is

Our leading-edge technology, the shortest cycle times in the industry, advanced business processes, and global presence help our clients reduce unit operation costs.

Dresser-Rand axial compressor.





The D-R axial compressor line includes seven standard frame sizes – each available with multiple stage configurations. Each stage configuration is designed to meet your requirements at optimum efficiency.



Axial compressor flow coverage chart.

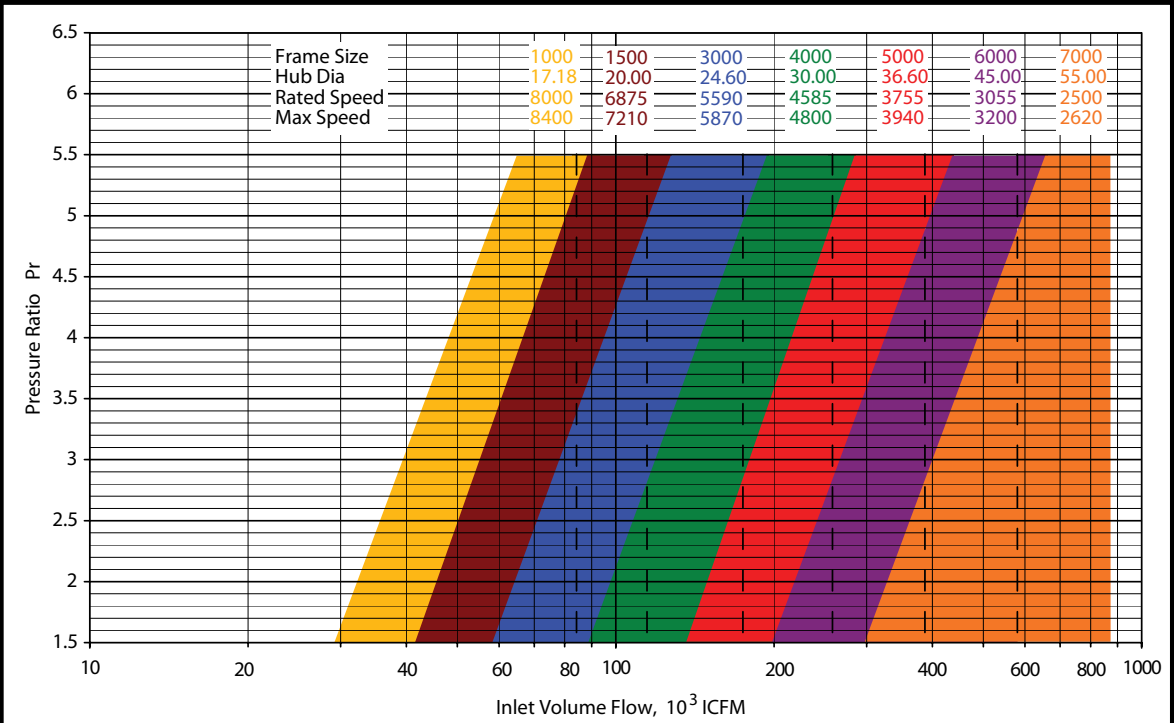

D

esign features

Innovative design, and superior components.

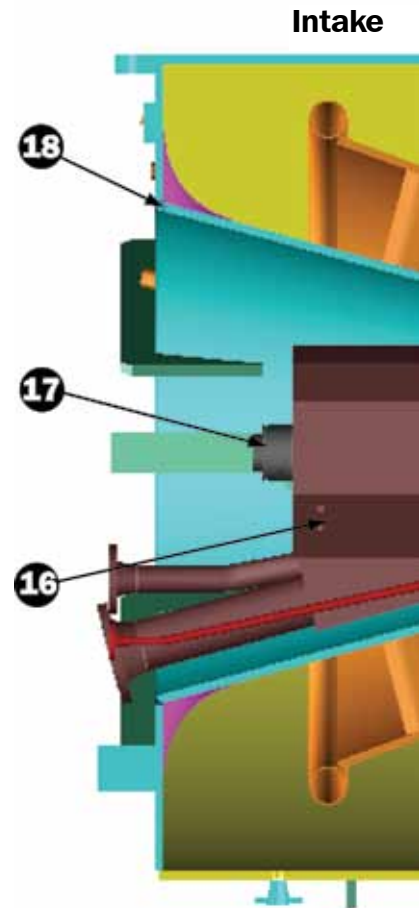
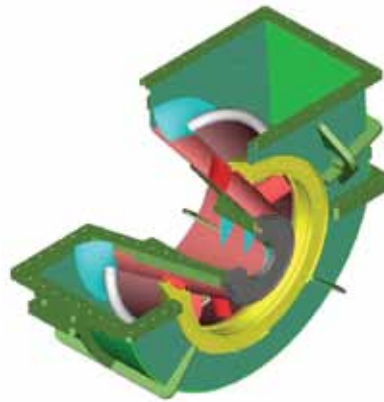

D-R's axial compressors are very reliable and require only simple maintenance. The horizontally split design provides easy accessibility and variable stator adjustment via external drive rings.

Intake and discharge volutes are either fabricated or cast steel and can be arranged upward or downward. The intake volute has flow taps that provide calibrated flow measurement.

The cast steel **stator casing**, located in the compressor center section between the intake and discharge volutes, is a two-piece design.

Stator vanes are available in three arrangements: fixed; individually adjustable; or continuously adjustable. Fixed vanes are typically used in variable speed applications. Individually adjustable vanes allow future changes

in operating characteristics or occasional blade adjustments. Continuously adjustable vanes with automatic control are usually used in constant-speed applications with frequent changes or fluctuations in operating conditions. These vanes are adjusted simultaneously by a drive ring linked to a drive shaft that is automatically adjusted by a self-contained electro/hydraulic actuator system.



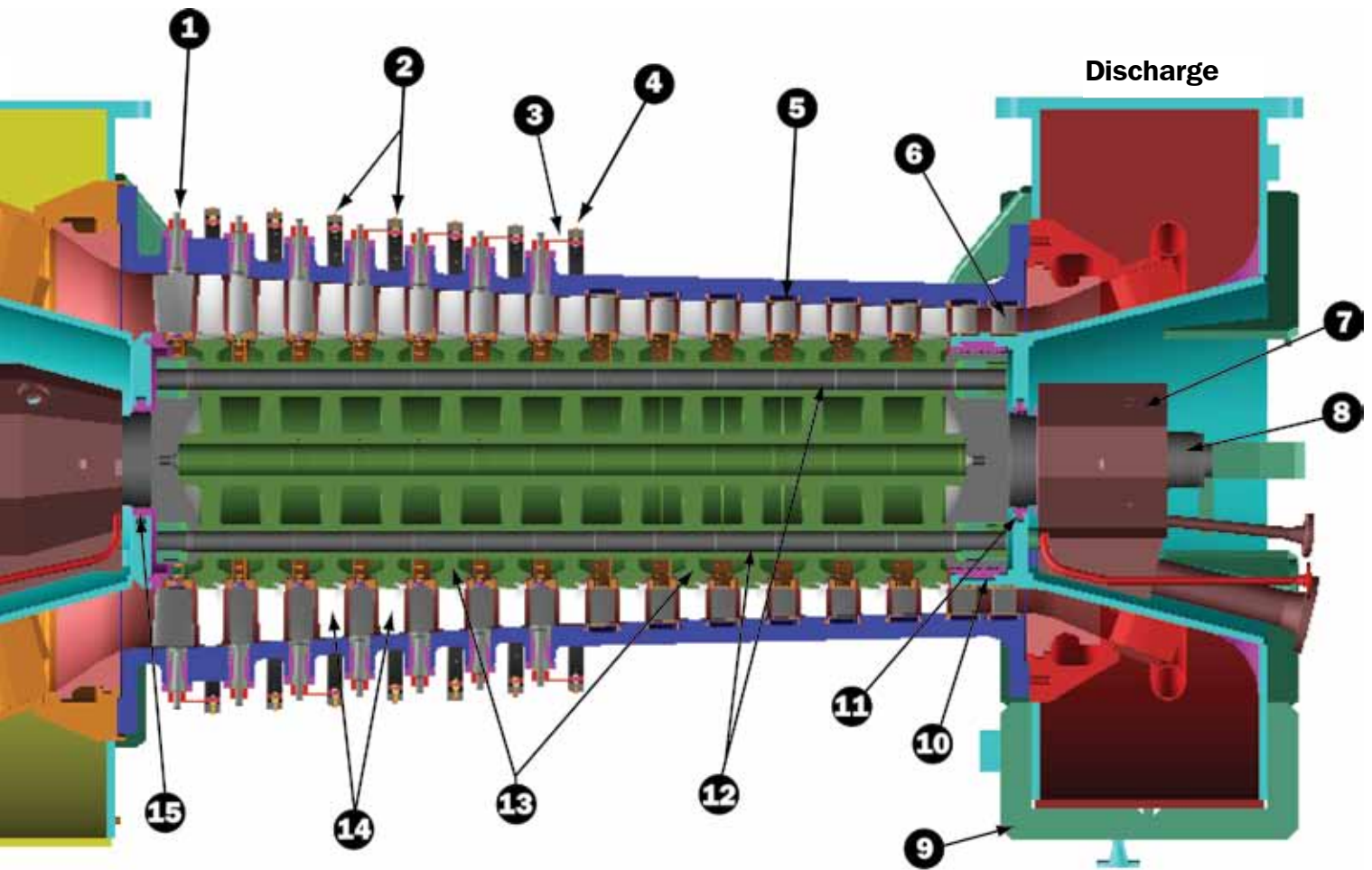

Rotor construction can be either disc-on-shaft or tie-bolt, depending on the number of stages. Rotor blades are made from a chrome-based stainless steel that does not require coatings. The inner end forms a dovetail section that fits into a mating slot in the rotor disc. Blades are held in place axially by removable clips and can be easily replaced in the field if necessary without removing the rotor.

Bearing housings are horizontally split for easy access to

all bearing parts without disassembling the volutes or casing. The bearing housing brackets are bolted and doweled to the casing for positive, permanent alignment.

Bearings (journal and thrust) are available in several designs (sleeve, tilt pad, self-leveling, self-equalizing). These designs incorporate either flooded or directed lubrication schemes. Our expertise allows us to successfully apply these designs as retrofits to existing equipment or as part of a new unit.

Part No.	Part Name	Material
1	Inlet Guide Vane	Stainless Steel
2	Stator Vane	Stainless Steel
3	Spring Link	Stainless Steel
4	Drive Ring	Stainless Steel
5	Stator Casing	Cast Steel
6	Discharge Guide Vane Assembly	Stainless Steel
7	Plain Bearing Body & Cap	Steel
8	Stub Shaft (plain bearing end)	Alloy Steel
9	Discharge Volute Assembly	Fab Steel
10	Discharge Seal	Aluminum
11	Laby. Packing Ring	Cast Aluminum
12	Tie Bolt	Alloy Steel
13	Rotor Disk	Alloy Steel
14	Rotor Blade	Stainless Steel
15	Laby. Packing Ring	Cast Aluminum
16	Thrust Bearing Body & Cap	Steel
17	Stub Shaft (thrust bearing end)	Alloy Steel
18	Intake Volute Assembly	Fab Steel



Technological advantages

*We deliver innovative products,
custom tailored to individual needs.*



Installing axial air compressor rotor into compressor housing.

FOCUSED ON PERFORMANCE IMPROVEMENTS

D-R's axial compressor design is continually reviewed for improvement. Performance improvements in existing units can be provided to maximize flow and efficiency. Incremental options usually exist for cost-effective revamps or rerates of an existing axial compressor. Existing units can be upgraded or retrofitted to adapt to your present operating conditions and requirements. These

upgrades include reinforced variable stator drive rings, replacement of the pneumatic/hydraulic actuator system with a self-contained electro/hydraulic actuator, variable stator inner hardware, spring links, rotor blade material that does not require coating, as well as new blade designs for added performance.

DYNAMIC SIMULATION ANALYSIS

D-R has invested in technology to perform dynamic simulations on power recovery trains using proprietary software. These dynamic simulation studies predict the system response to a variety of upsets such as trips, valve failures, coupling breakage, etc. Parametric studies of items such as valve sizes, stroke times, and controller gains are conducted. Configurations can be evaluated without physically building the system. Controller stability can be demonstrated over extended periods.

BLADE STRESS AND FREQUENCY ANALYSIS

D-R has sophisticated blade stress and frequency analysis capabilities. Steady state stresses of the blade airfoil attachment and disc may be calculated for any operating point of interest. The same finite element model is then used to calculate natural frequencies and mode shapes, including the coupled influence of the disc-on-blade resonances. Campbell diagrams may be created to determine potential interferences. These frequencies are then used to calculate the associated dynamic stress.

Post-processing routines enable plotting of stresses of any of the blade/disk combinations, in addition to traditional Campbell, and Goodman diagrams.

CFD ANALYSIS

D-R maintains a staff of engineers to perform computational fluid dynamics (CFD) analysis on a wide range of products, including centrifugal and axial compressors, hot gas expanders, and steam and gas turbines. CFD is an integral part of the new equipment design cycle and is routinely used to make design improvements on installed machines. D-R continues to use sophisticated computational tools to produce some of the most advanced engineered products on the market.

UNIGRAPHICS

Unigraphics (UG) CAD/CAM software is D-R's standard design platform. With its advanced solid modeling capability, and its capacity to deliver art-to-part products, the UG system enables us to offer competitive solutions for our clients.

The Unigraphics CAD/CAM system further enhances the company's ability to design and manufacture products of the highest quality. Unigraphics has been used in the design of our DATUM® centrifugal compressor product line, our VECTRA® power turbine product line, as well as our power recovery machinery. Unigraphics enables concurrent engineering and provides an environment that

allows engineers to integrate their work through the entire design, analysis, and manufacturing process. Unigraphics and its 3-D solid modeling capabilities allow engineers to handle more projects with substantially reduced cycle times.

ROTOR DYNAMICS

D-R uses two rotor dynamic programs, lateral and torsional. The lateral program permits the calculation of rotor-bearing-support, undamped natural frequencies, fluid film bearing, and seal characteristics, synchronous response to unbalance, rotor-bearing-support damped natural frequencies, and labyrinth seal characteristics. The torsional programs permit the calculation of train-lateral, steady-state frequencies, and response to the acceleration of synchronous and variable speed electric motors. They represent current, state-of-the-art application in rotor dynamics analysis.

CONTROL SYSTEMS

Dresser-Rand supplies control systems for compressor, generator, and related turbomachinery applications. The DI-Tronics control system is programmable logic controller (PLC) - based, and features a Windows-based color graphics operator interface. The system can be configured to control, monitor, and protect a variety of machinery types including gas turbine, steam turbine, motor, and expander-driven trains as well as associated turbomachinery applications.

The PLC-based control system provides gas turbine fuel control, steam turbine governor control, compressor surge control, machine vibration and temperature monitoring, train sequencing, and machinery protection, all of which are

integrated into the PLC. The user-friendly operator interface system features graphic and test-based screens, real-time, and historical trending, report generation, as well as alarm, shutdown, and event logging capabilities. The PLC and operator interface systems can be field modified by the operator, if required.

TESTING CAPABILITIES

At the Dresser-Rand facility in Le Havre, France, we have seven compressor test stands for mechanical and performance testing, and two full-load testing stands, including hydrocarbon testing. In Olean, New York, the Dresser-Rand facility has several test stands capable of testing gas turbine-driven compression trains to

more than 100 MW, including full hydrocarbon capability. Test capabilities include the following:

- String
- Generator set full-load
- Package testing with contract equipment
- Generator set load-response
- Parallel testing of generator sets
- Compressor full-load/full-pressure hydrocarbon
- Gas turbine dynamometer load (proprietary units only)
- Noise and vibration
- Acoustic enclosure integrity
- Fire-extinguishing
- Auxiliary system module
- Control panel

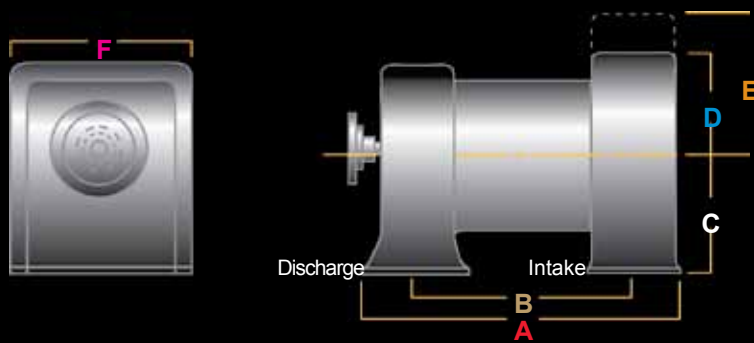

Weights and Dimensions

Frame Size	Nominal Speed RPM	Capacity Ranges CFM/MM ³ (HR)	Inlet				Discharge		No. of Stages	A	B	Total Weight Lbs (Kg)	Rotor Weight Lbs (Kg)	Top Half Weight Lbs (Kg)
			Size inches (MM)	Dimensions: inches (MM)				Size inches (MM)						
				C	D	E	F							
1000	8000	75000 (127426)	31 x 55 (787 x 1397)	36 (914)	29 (737)	44 (1118)	62 (1575)	27 x 45 (686 x 1143)	15	129 (3276)	100 (2540)	17600 (7983)	3000 (1361)	8800 (3992)
1500	6870	110000 (186891)	37 x 66 (940 x 1676)	46 (1168)	41 (1041)	58 (1473)	87 (2210)	32 x 62 (813 x 1575)	15	149 (3785)	116 (2946)	26000 (11794)	4800 (2177)	13000 (5897)
3000	5590	160000 (271842)	42 x 85 (1067 x 2159)	35 (889)	38 (965)	60 (1524)	108 (2743)	30 x 73 (762 x 1854)	15	166 (4216)	130 (3302)	36000 (16328)	9300 (4218)	18000 (8164)
4000	4580	230000 (390772)	48 x 109 (1219 x 2769)	40 (1016)	38 (965)	65 (1651)	122 (3099)	34 x 88 (864 x 2235)	15	199 (5055)	158 (4013)	50800 (23043)	16600 (7529)	25400 (11521)
5000	3750	340000 (577664)	60 x 126 (1524 x 3200)	52 (1321)	59 (1499)	90 (2286)	149 (3785)	37 x 95 (940 x 2413)	15	247 (6274)	194 (4928)	74400 (33748)	25900 (11747)	37200 (16874)
6000	3120	500000 (849505)	78 x 142 (1981 x 3607)	54 (1372)	51 (1295)	97 (2464)	146 (3708)	40 x 101 (1016 x 2565)	15	261 (6629)	215 (5461)	107000 (48535)	41300 (18734)	53500 (24268)
7000	2500	700000 (1190000)	92 x 202 (2337 x 5131)	77 (1956)	84 (2134)	154 (3912)	210 (5334)	66 x 166 (1676 x 4216)	15	406 (10312)	289 (7341)	276800 (125800)	82600 (37545)	100900 (45860)

DRESSER-RAND®

Bringing energy and the environment into harmony.®

For more information on **axial compressors**, contact us at:

Dresser-Rand

Paul Clark Drive
Olean, NY 14760
Tel: (Int'l +1) 716-375-3000
Fax: (Int'l +1) 716-375-3178

For a complete list of products and services, visit: **www.dresser-rand.com** or contact the following:

CORPORATE HEADQUARTERS

Dresser-Rand

West8 Tower, Suite 1000
10205 Westheimer Road
Houston, Texas 77042
Tel: (Int'l +1) 713-354-6100
Fax: (Int'l +1) 713-354-6110

Dresser-Rand

112, Avenue Kleber
Cedex 16
Paris 75784 France
Tel: (Int'l +33) 156 26 71 71
Fax: (Int'l +33) 156 26 71 72

Email: info@dresser-rand.com

REGIONAL HEADQUARTERS

The Americas

West8 Tower, Suite 1000
10205 Westheimer Road
Houston, Texas 77042
Tel: (Int'l +1) 713-354-6100
Fax: (Int'l +1) 713-354-6110

EMEA

(Europe, Middle East & Africa)
Dresser-Rand S.A.
31 Boulevard Winston Churchill
Cedex 7013
Le Havre 76080 France
Tel: (Int'l +33) 2-35-25-5225
Fax: (Int'l +33) 2-35-25-5366/5367

Asia-Pacific

Dresser-Rand Asia Pacific Sdn Bhd
Unit 9-4, 9th Floor
Bangunan Malaysian Re
17 Lorong Dungun
Damansara Heights
50490 Kuala Lumpur, Malaysia
Tel: (Int'l +60) 3-2093-6633
Fax: (Int'l +60) 3-2093-2622

©2008 Dresser-Rand.
Printed in U.S.A.

This brochure comprises a general overview of the Dresser-Rand products described herein. It is solely for informational purposes, does not represent a warranty or guarantee of the information contained herein, and is not to be construed as an offer to sell or solicitation to buy. Contact Dresser-Rand for detailed design and engineering information suitable to your specific applications. Dresser-Rand reserves the right to modify its products and related product information at any time without prior notice.