

Gimpel™ Valves Assembly Dimensions

Oil Operated Trip Valve OOTV (Inverted Offset Body)

6" to 24" CL600 to 2500

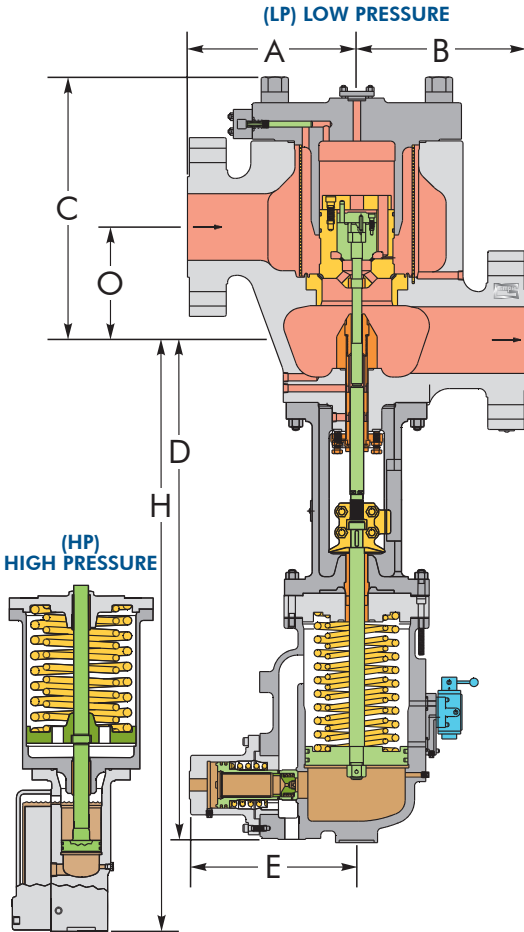

(HP) HIGH PRESSURE

CYLINDER DIAMETER	DIMENSION E
4.00	9.12
5.00	
6.00	
6.25	
7.75	

(LP) LOW PRESSURE

CYLINDER DIAMETER	DIMENSION E
6.00	10.25
7.00	14.70
8.00	14.70
10.00	13.60
11.00	17.80
13.00	22.00
14.00	15.75
15.00	22.00
17.00	18.62
18.50	24.30
20.00	24.50
22.00	25.50

SIZE NPS	PRESSURE CLASS	EST. WT. (LBS)	DIMENSIONS (INCHES)					
			A	B	C	D	O	H
4	600*					51.00	7.00	64.00
	900*							
	1500*							
	2500	3000-3600	15.75	15.75	29.00			
6	600*					52.00	11.00	65.50
	900*							
	1500	3000-3800	16.00	16.00	34.40			
	2500*							
8	600*					53.00	12.00	67.12
	900*							
	1500	4500-5300	18.00	18.00	29.50			
	2500	6500-7400	22.00	22.00	32.50			
10	600	4000-4500	23.31	23.31	30.00	62.50	14.75	73.64
	900	4200-4700	24.19	24.19	31.75			
	1500	6500-7000	22.50	22.50	33.25			
	2500	9000-9500	26.00	26.00	36.00			
	600*							
12	900	5600-6800			35.50	66.30	16.50	74.64
	1500	8800-9200	24.75	24.75	40.75			
	2500	12000-13000	29.50	29.50	45.00			
	600*							
14	900	5000-6000	23.00	23.00	35.40	66.20	16.50	76.40
	1500	12000-13000	26.60	26.60	45.60			
	2500*							
	600*							
16	900	8000-9000	28.00	28.00	39.50	80.00	21.00	78.40
	1500	15000-16000	31.50	31.50	47.24			
	2500	20000-21000	35.00	35.00	53.00			
	600	12000-13000	34.00	34.00	48.00			
18	900*					24.00	78.86	
	1500*							
	2500*							
	600	15000-16000	32.00	32.00	52.00			
20	900*					77.00	26.00	80.00
	1500*	23000-25000	36.00	36.00	60.00			
	2500*							
	600	19000-20000	34.00	34.00	62.00			
24	900*					30.00	85.00	
	1500*							
	2500*							

*Refer to Dresser-Rand

NOTE:

- This drawing is for information purposes only. Do not use for construction.
- Information contained herein is subject to change without notice.
- All dimensions are in INCHES. All weights are in POUNDS.
- Dimension "D" will vary with cylinder size used, maximums given. Dresser-Rand must advise cylinder size needed for operation at steam conditions to be specified by customer.
- Weight ranges given are intended as a guide. Actual weights can be advised by Dresser-Rand.
- Welding end inlet and outlet connections can be furnished.

Gimpel™ Valves Assembly Dimensions

Oil Operated Trip Valve OOTV (Inverted Offset Body)

DRESSER-RAND

DRAWING
NUMBER

L-4933

REV
D