

Gimpel™ Valves Assembly Dimensions

Oil Operated Trip Throttle Valve OOTTV (Inverted, Offset Body) 3" to 24" CL600 to 2500

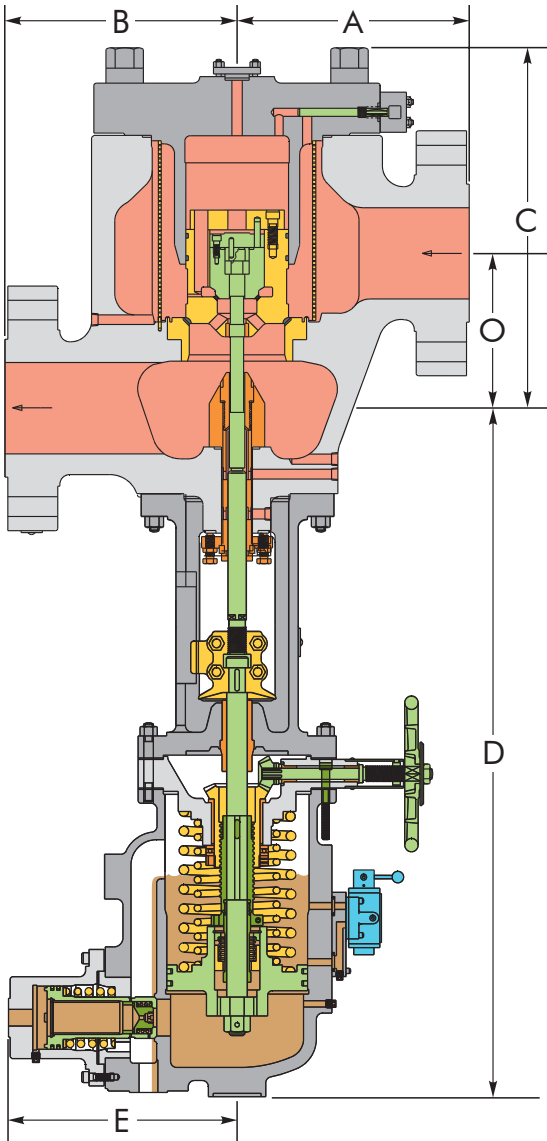

CYLINDER DIAMETER	DIMENSION E
8.00	14.70
11.00	17.80
13.00	22.00
15.00	22.00
18.50	24.30

SIZE NPS	PRESSURE CLASS	EST. WT. (LBS)	DIMENSIONS (INCHES)				
			A	B	C	D	O
3	600*						
	900*						
	1500*						
	2500*						
4	600*						
	900*						
	1500*						
	2500*						
5	600*						
	900*						
	1500*						
6	600*						
	900*						
	1500*		16.00	16.00	34.40		11.00
8	600*						
	900*						
	1500	4500-5300	18.00	18.00	28.25	62.12	12.00
10	600*						
	900*						
	1500	6500-7000	22.50	22.50	31.75	70.00	14.00
12	600*						
	900*	5600-6900			35.50	75.00	16.50
	1500	8800-9200	24.75	24.75	40.75		
14	600*						
	900*	5000-6000	23.00	23.00	35.40	74.00	16.50
	1500	12000-13000	26.60	26.60	45.60		19.00
16	600*						
	900*						
	1500	15000-16000	31.50	31.50	47.24	76.00	22.00
18	600*						
	900*						
	1500*						
20	600*	15000-16000	32.00	32.00	52.00	77.00	26.00
	900*						
	1500*	23000-25000	36.00	36.00	60.00	81.00	26.00
24	600*						
	900*						
	1500*						

*Refer to Dresser-Rand

NOTE:

- This drawing is for information purposes only. Do not use for construction.
- Information contained herein is subject to change without notice.
- All dimensions are in INCHES. All weights are in POUNDS.
- Dimension "D" will vary with cylinder size used. Maximums given. Dresser-Rand must advise cylinder size needed for operation at steam conditions to be specified by customer.
- Weight ranges given are intended as a guide. Actual weights can be advised by Dresser-Rand.
- Also available with HP actuator. Please contact Dresser-Rand for information.

Gimpel™ Valves Assembly Dimensions Oil Operated Trip Throttle Valve OOTTV (Inverted, Offset Body)

DRESSER-RAND

DRAWING
NUMBER

L-4935